

# INSTRUCTION MANUAL

Area Sensor Ultra-slim Body  
**NA1-5 Series**

Thank you very much for using SUNX products. Please read this Instruction Manual carefully and thoroughly for the correct and optimum use of this product. Kindly keep this manual in a convenient place for quick reference.

## WARNING

- If this product is used as a sensing device for personnel protection, serious body injury or death could result.
- Never use this product as a sensing device with any press machine, shearing machine, roll grinding machine, forming machine, vulcanizer, or robot etc. for protection of a hand or a part of the body.
- This product does not include a self-checking circuit for safety functions necessary to allow its use as a safety device. Thus, a system failure or malfunction can result in either an energized or a de-energized output condition.
- When this product is used as a sensing device in the following applications and if a problem relating to 'law' or 'product liability' occurs, SUNX shall not be liable for the failure and for the damage or less.
  - 1) Use of this product installed to a machinery or a device as a sensing device to detect a hand or a part of the operator's body entering a dangerous area and stop the machinery or the device.
  - 2) Installation of this product to a protection device for preventing to enter a dangerous area and use of this as a sensing device which detects a hand or a part of the operator's body and open / close the door or window.
  - 3) Use of this product as a sensing device for personnel protection (including interlock).
- For sensing devices to be used as safety devices for press machines or for personnel protection, use products which meet standards, such as OSHA, ANSI or IEC etc., for personnel protection applicable in each region or country.
- In case of using as a safety device for press machines in Japan, use a product approved by the Ministry of Health, Labor and Welfare of Japan.

## 1 SPECIFICATIONS

Item	Type	Long sensing range		High-luminous job indicator	
		NPN output type	PNP output type	NPN output type	PNP output type
Model No. (Note 1)		<b>NA1-5</b>	<b>NA1-5-PN</b>	<b>NA1-PK5</b>	<b>NA1-PK5-PN</b>
Sensing height		100mm			
Sensing range (Note 2)		0.2 to 3m (0.05 to 1m when set to SHORT)		0.1 to 1.2m (0.05 to 0.5m when set to SHORT)	
Beam pitch		25mm			
Number of beam channels		5 beam channels			
Sensing object		φ35mm or more opaque object			
Supply voltage		12 to 24V DC ±10% Ripple P-P 10% or less			
Power consumption (Note 3)		Emitter: 0.5W or less Receiver: 0.8W or less	Emitter: 0.6W or less Receiver: 0.9W or less	Emitter: 0.5W or less Receiver: 0.8W or less	Emitter: 0.6W or less Receiver: 0.9W or less
Output		<b>&lt;NPN output type&gt;</b> NPN open-collector transistor • Maximum sink current: 100mA • Applied voltage: 30V DC or less (between output and 0V) • Residual voltage: 1V or less (at 100mA sink current) 0.4V or less (at 16mA sink current)		<b>&lt;PNP output type&gt;</b> PNP open-collector transistor • Maximum source current: 100mA • Applied voltage: 30V DC or less (between output and +V) • Residual voltage: 1V or less (at 100mA source current) 0.4V or less (at 16mA source current)	
Output operation		ON or OFF when one or more beams are interrupted / ON or OFF when two or more beams are interrupted, selectable by operation mode switch			
Short-circuit protection		Incorporated			
Response time		10ms or less (when the interference prevention function is used, in Light state: 30ms or less, in Dark state: 13ms or less)			
Interference prevention function		Incorporated			
Ambient temperature		-10 to +55°C (No dew condensation or icing allowed), Storage: -20 to +70°C			
Ambient humidity		35 to 85% RH, Storage: 35 to 85% RH			
Emitting element		Infrared LED (synchronized scanning system)			
Material		Enclosure: Heat-resistant ABS, Lens: Acrylic, Indicator cover: Acrylic			
Cable		0.3mm <sup>2</sup> 4-core (emitter: 3-core) oil-resistant cable, 2m long			
Weight (total of the emitter and the receiver)		Emitter: 70g approx., Receiver: 80g approx.		Emitter: 80g approx., Receiver: 85g approx.	

Notes: 1) The model No. with suffix '-C5' is 5m cable length type. (only the long sensing range: NPN output type)

Model No.: **NA1-5-C5**

The model No. with suffix '-J' is pigtailed type. (cable length: 0.3m)

(e.g.) **NA1-5-J**

For the cable connected with the pigtailed type, use the connection cable **CN-24-C2** (cable length: 2m) (optional) or **CN-24-C5** (cable length: 5m) (optional).

- 2) The sensing range gives the mounting distance between the emitter and the receiver. In case of **NA1-5(-PN)**, an object can be detected even if it is 0.2m or less (0.05m or less when set to SHORT) away, and in case of **NA1-PK5(-PN)**, it can be detected even if it is 0.1m or less (0.05m or less when set to SHORT) away.

- 3) Obtain the current consumption by the following equation.

$$\text{Current consumption} = \frac{\text{Power consumption}}{\text{Supply voltage}}$$

(e.g.) When the supply voltage is 12V, the current consumption of the **NA1-5** emitter is:  
 $0.5W \div 12V = 0.042A = 42mA$

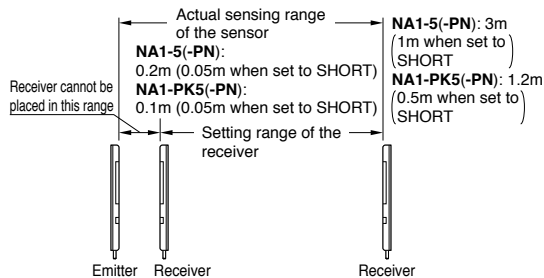

## 2 CAUTIONS

- This product has been developed / produced for industrial use only.
- Make sure to carry out the wiring and the operation of the operation mode switches in the power supply off condition.
- Take care that wrong wiring may damage the sensor.
- Verify that the supply voltage variation is within the rating.
- If power is supplied from a commercial switching regulator, ensure that the frame ground (F.G.) terminal of the power supply is connected to an actual ground.
- In case noise generating equipment (switching regulator, inverter motor, etc.) is used in the vicinity of this sensor, connect the frame ground (F.G.) terminal of the equipment to an actual ground.
- Do not run the wires together with high voltage lines or power lines or put them in the same raceway. This can cause malfunction due to induction.

- Do not use during the initial transient time (0.5 sec.) after the power supply is switched on.
- Extension up to total 100m is possible with a 0.3mm<sup>2</sup>, or more, cable. However, in order to reduce noise, make the wiring as short as possible.
- Avoid dust, dirt, and steam.
- Take care that the sensor does not come in contact with water, oil, grease, organic solvents, such as, thinner etc., or strong acid, and alkaline.
- Take care that the sensor is not directly exposed to fluorescent light from a rapid-starter lamp or a high frequency lighting device, as it may affect the sensing performance.
- The emitter and the receiver must face each other correctly. If one of them is set upside down, the sensor does not work.
- This sensor is suitable for indoor use only.

## 3 MOUNTING

- Use M4 screws with washers, and M4 nuts. The tightening torque should be 0.5N·m or less. (Please arrange the screws and nuts separately.)

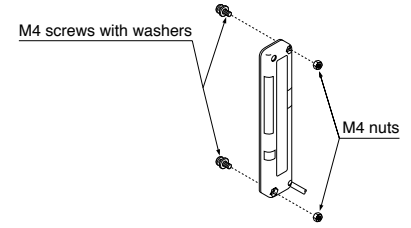

- Optional sensor mounting brackets (**MS-NA1-1**, **MS-NA2-1**) are also available.

## 4 I/O CIRCUIT DIAGRAMS

- **NPN output type**

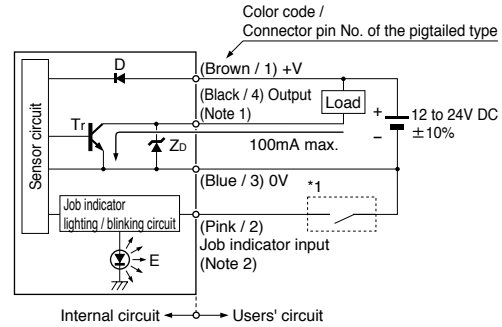

Notes: 1) The emitter is not incorporated with the output.

- 2) In order to use the job indicators as large size operation indicators, connect the job indicator input (pink) and output (black) wires together.

Symbols... D : Reverse supply polarity protection diode  
 Zd : Surge absorption zener diode  
 Tr : NPN output transistor  
 E : Job indicator

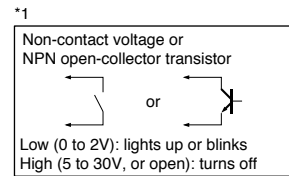

- **PNP output type**

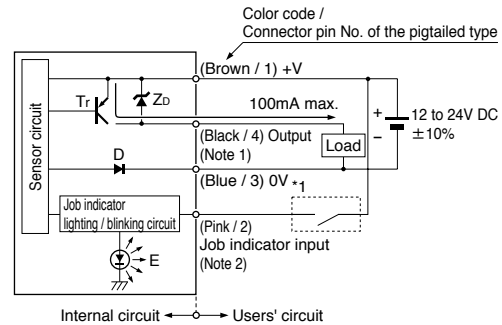

Notes: 1) The emitter is not incorporated with the output.

- 2) In order to use the job indicators as large size operation indicators, connect the job indicator input (pink) and output (black) wires together.

Symbols... D : Reverse supply polarity protection diode  
 Zd : Surge absorption zener diode  
 Tr : PNP output transistor  
 E : Job indicator

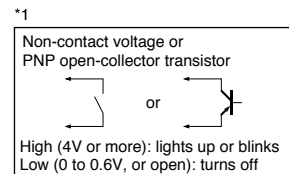

- **Connector-pin position (Pigtailed type)**

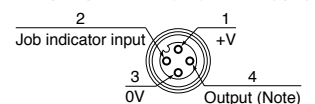

Note: No connection is required for the emitter.

## 5 PART DESCRIPTION

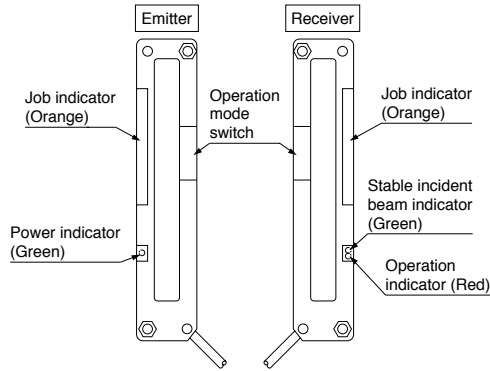

## 6 SELECTION OF OPERATION

### ● Selection of output operation

- The output operation mode is selected by the operation mode switch on the receiver.

(Make sure that the power is off while setting. The operation mode does not change even if the setting is changed in the power supply on condition.)

Operation mode switch		Output operation	Operation indicator
SINGLE	D-ON SINGLE D/ON	ON when one or more beams are interrupted.	Lights up when the output is ON.
	L-ON DOUBLE L/ON	OFF when one or more beams are interrupted. (ON when all beams are received.)	Lights up when the output is OFF.
DOUBLE	D-ON SINGLE D/ON	ON when any two or more beams are interrupted.	Lights up when the output is ON.
	L-ON DOUBLE L/ON	OFF when any two or more beams are interrupted.	Lights up when the output is OFF.

Note: FREQ. A / FREQ. B and LIGHT / FLASH selection switches are not related to the output operation selection.

### ● Job indicator operation selection

- Lighting / blinking is selected by the operation mode switch on the emitter and the receiver.

(Make sure that the power is off while setting. The operation mode does not change even if the setting is changed in the power supply on condition.)

Operation mode switch		Job indicator
LIGHT	Emitter LIGHT FLASH	Lighting
	Receiver LIGHT FLASH	
FLASH	Emitter LIGHT FLASH	Blinking
	Receiver LIGHT FLASH	

Note: FREQ. A / FREQ. B, SINGLE / DOUBLE and LONG / SHORT selection switches are not related to the setting of job indicator.

## 7 BEAM AXIS ALIGNMENT

- Place the emitter and the receiver face to face along a straight line.
- After the cable has been correctly connected, switch the power ON.
- Move the emitter in the up, down, left and right directions, in order to determine the range of the beam received condition with the help of the operation indicator (red) on the receiver. Then, set the emitter at the center of this range.
- Similarly, adjust for up, down, left and right angular movement of the emitter.
- Further, perform the angular adjustment for the receiver also.
- Check that the stable incident beam indicator (green) lights up.
- Interrupt each beam channel with the actual sensing object, and confirm that the sensor operates correctly.

Note: The stable incident beam indicator (green) lights up when all the five light beams are stably received by the receiver.

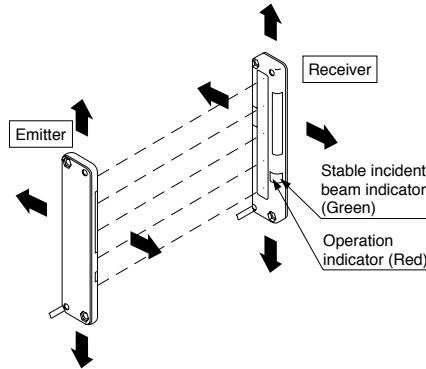

## 8 INTERFERENCE PREVENTION FUNCTION

- By setting different emission frequencies, two sets of sensors can be mounted close together, as shown in the figure below.

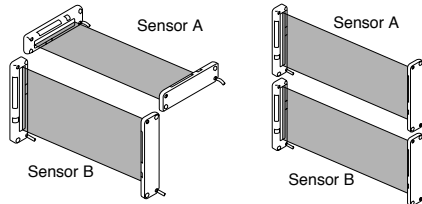

### ● Frequency setting

- Set the frequency of Sensor A to FREQ. A (on the emitter and the receiver) and that of Sensor B to FREQ. B (on the emitter and the receiver).

(Make sure that the power is off while setting. The operation mode does not change even if the setting is changed in the power supply on condition.)

	Operation mode switch			
	Emitter		Receiver	
Sensor A (FREQ. A)	FREQ. A	FREQ. B	FREQ. A	FREQ. B
Sensor B (FREQ. B)	FREQ. A	FREQ. B	FREQ. A	FREQ. B

Note: LIGHT / FLASH, SINGLE / DOUBLE and LONG / SHORT selection switches are not related to the interference prevention function.

## 9 LONG / SHORT SELECTION SWITCH (incorporated in the emitter)

- Select the switch setting according to the setting distance L between the emitter and the receiver as given below.

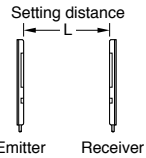

(Make sure that the power is off while setting. The operation mode does not change even if the setting is changed in the power supply on condition.)

Setting distance L		Operation more switch (Emitter)	
NA1-5(-PN)	NA1-PK5(-PN)	LONG	SHORT
0.05 to 1m (0.05m ≤ L ≤ 1m)	0.05 to 0.5m (0.05m ≤ L ≤ 0.5m)	SHORT	LONG
1 to 3m (1m ≤ L ≤ 3m)	0.5 to 1.2m (0.5m ≤ L ≤ 1.2m)	LONG	SHORT

## 10 FIXING OF SENSOR MOUNTING BRACKET (OPTIONAL)

### ● Assembly diagram for MS-NA1-1

- M4 screws with washers, nuts and hooks are attached with MS-NA1-1.

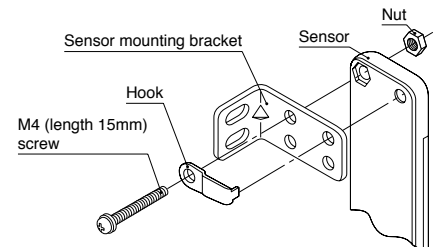

### ● Assembly diagram for MS-NA2-1

- M4 screws with washers, nuts, hooks and spacers are attached with MS-NA2-1.

### Rear mounting

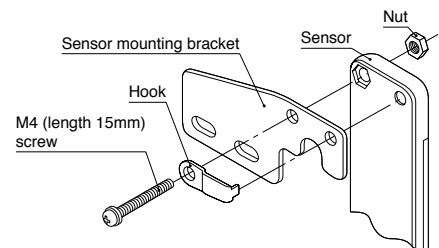

### Front mounting

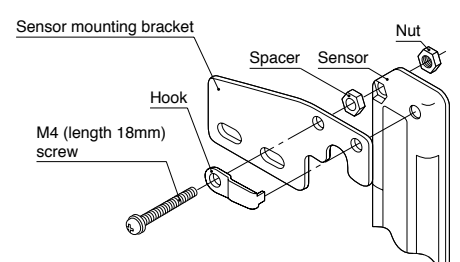

## 11 INTENDED PRODUCTS FOR CE MARKING

- The models listed under 'SPECIFICATIONS' come with CE Marking. As for all other models, please contact our office.



## SUNX Limited

URL : sunx.jp

Overseas Sales Dept. (Head Office)  
2431-1 Ushiyama-cho, Kasugai-shi, Aichi, 486-0901, Japan  
Phone: +81-(0)568-33-7861 FAX: +81-(0)568-33-8591

Europe Headquarter: Panasonic Electric Works Europe AG  
Rudolf-Diesel-Ring 2, D-83607 Holzkirchen, Germany  
Phone: +49-8024-648-0

US Headquarter: Panasonic Electric Works Corporation of America  
629 Central Avenue New Providence, New Jersey 07974 USA  
Phone: +1-908-464-3550

PRINTED IN JAPAN